

SECTION 7

STREETS

7-1 STREET CLASSES AND DESIGN WIDTHS – For purposes of geometric and structural design of all new public streets, streets shall be classified according to the following requirements, the appropriate Standard Drawings, and Table 7-1. Under certain circumstances, particularly within the infill areas of the City, changes to the standards can be made at the discretion of the City Engineer.

A. 20-Foot Street (Alley) – A Street depressed in the center with a right-of-way and surface width of 20 feet. Alleys are not permitted unless specifically approved by the City Council. STD DWG #ST-1A

B. Residential Streets – Where residential streets serve Low Density Residential (LDR) and Medium Density Residential (MDR) subdivisions, the following standards apply. In the case of High Density Residential (HDR) and (MDR) condominium development, please refer to City of Roseville Fire Department for minimum street sections.

LDR	MDR		HDR
	Fee Lot	Condo Style	
Public Works Standards	Public Works Standards	Fire Department Standards	Fire Department Standards

1. Minor Residential with Attached Sidewalks – A residential street servicing 100 or fewer lots shall be classified as a minor residential street. Minor residential streets shall have a right-of-way width of 42 feet, and back of curb to back of curb width of 34 feet. STD DWG #ST-2

2. Minor Residential with Detached Sidewalks – A residential street servicing 100 or fewer lots shall be classified as a minor residential street. Minor residential streets shall have a right-of-way width of 54 feet and a back-of-curb to back-of-curb width of 34 feet. STD DWG #ST-3

3. Primary Residential with Attached Sidewalks – A residential street servicing more than 100 lots or along which schools or parks are proposed to front, shall be classified as a primary residential street. Primary residential streets shall have a right-of-way width of 46 feet, and back of curb to back of curb width of 38 feet. STD DWG #ST-4

4. Primary Residential with Detached Sidewalks – A residential street servicing more than 100 lots or along which

schools or parks are proposed to front, shall be classified as primary residential. Primary residential streets shall have a right-of-way width of 58 feet and back-of-curb to back-of-curb width of 38 feet. STD DWG #ST-5

C. Collector/Industrial – A Street serving an industrial/commercial subdivision or a residential subdivision along which no home frontage is allowed shall be classified as a collector/industrial street. Collector/industrial streets shall have a right-of-way width of 58 feet, and back-of-curb to back-of-curb width of 48 feet. Additional right-of-way and pavement shall be provided at intersections for deceleration lanes, bus turnouts, and turn lanes, as specified by the City Engineer. STD DWG #ST-7

D. Minor Arterial – Those roads specified in the City's Capital Improvement Program as requiring a four-lane roadway shall be classified as minor arterials. Minor arterial shall have a right-of-way and back-of-curb to back-of-curb width of 76 feet, and shall provide a center 2-way left lane or raised landscape median as specified by the City Engineer. Additional right-of-way and/or pavement may be required for bus turnouts and at intersections and driveways for acceleration lanes, deceleration lanes, and multiple left turn lanes, as specified by the City Engineer. Additional right-of-way shall also be provided if sidewalks are not part of a landscape/pedestrian corridor adjacent to the back of curb. STD DWG #ST-8

E. Major Arterial – Those roads specified in the City's Capital Improvement Program as requiring a six-lane roadway shall be classified as major arterials. Major arterials shall have a right-of-way width of 100 feet and back-of-curb to back-of-curb width of 100 feet. Additional right-of-way and/or pavement may be required for bus turnouts and at intersections and driveways for acceleration lanes, deceleration lanes, and multiple left turn lanes, as specified by the City Engineer. Additional right-of-way shall also be provided if sidewalks are not part of a landscape/pedestrian corridor adjacent to the back of curb. STD DWG #ST-9

F Cul-de-Sac – The length of cul-de-sac streets as measured from the centerline of the intersecting street to the center of the bulb, shall not exceed 500 feet, unless a secondary emergency vehicle access is provided to the rear of the cul-de-sac bulb area, in which case the length of the cul-de-sac may be increased to maximum length of 1000 feet with the approval of the Fire Chief and City Engineer.

In the case of stub streets associated with phased development, the combined street lengths as measured from the dead-end to the nearest through street shall be in accordance with the requirements for cul-de-sacs. Stub streets shall be terminated with a temporary bulb or a hammerhead conforming to the Standard Drawing. A barricade conforming to the Standard Drawings shall be installed at the end of all

streets that are proposed for future extension. For cul-de-sacs greater than 200 feet or where the end of the cul-de-sac is not visible from the centerline intersection of cross street, a "NOT A THROUGH STREET" sign shall be installed at the beginning of cul-de-sacs. STD DWG #ST-14 & #ST-15

- G. Partial Width Streets** – At the discretion of the City Engineer, partial width streets may be permitted along the boundary of a subdivision of other private development where the full right-of-way width cannot be dedicated. For collector and arterial streets, the developer shall, as a minimum, dedicate sufficient right-of-way and construct 32 feet width of pavement with full frontage improvements along the developing property and a two-foot wide gravel shoulder on the opposite side. Street centerline and pavement crown shall be placed at the ultimate location. Partial streets will not be permitted for residential streets.
- H. Private Streets** – Private streets shall be designed to the same structural and geometric requirements as those for public streets. Minimum pavement widths shall be 28-feet, and curb and gutter sections shall have a 3-foot minimum width. Sidewalks on one side of the street can be eliminated at the discretion of the City Engineer.
- I. Gated Entryways** – Gated entryways are allowed in private subdivisions. Gate access must be provided in accordance with Fire Department requirements. They shall be designed per the standard drawing and shall be privately maintained. See STD DWG #ST-25

**TABLE 7-1
 STREET GEOMETRIC REQUIREMENTS**

CLASS	Right of Way Width	Back of Curb to Back of Curb Width	Radius of Curb Return at Right of Way & Back of Curb		No. of Travel lanes	Minimum Centerline Radius for Horizontal Curve
			ROW	BOC		
Minor Residential Attached Sidewalk	42 feet	34 feet	22 feet	26 feet	2	250 feet
Minor Residential Detached Sidewalk	54 feet	34 feet	16 feet	26 feet	2	300 feet
Primary Residential Attached Sidewalk	46 feet	38 feet	22 feet	26 feet	2	300 feet
Primary Residential Detached Sidewalk	58 feet	38 feet	16 feet	26 feet	2	500 feet
Collector/Industrial Attached Sidewalk	58 feet	48 feet	26 feet	31 feet	2	500 feet
Collector/Industrial Detached Sidewalk	48 feet	48 feet	26 feet	31 feet	2	500 feet
Minor Arterial	76 feet	76 feet	Residential 26 feet	31 Feet	4	1000 feet
			Collector/Industrial 26 feet	31 feet		
			Arterial w/o Accel Lane 50 feet	50 feet		
			Arterial w/Accel Lane 62 feet	62 feet		
Major Arterial	100 feet	100 feet	Residential 26 feet	31 Feet	6	2000 feet
			Collector/Industrial 26 feet	31 feet		
			Arterial w/o Accel Lane 50 feet	50 feet		
			Arterial w/Accel Lane 62 feet	62 feet		

7-2 RIGHT-OF-WAY WIDTH - Right-of-way widths shall be in accordance with these standards for the street classification under consideration or as

determined by the City Engineer. In no instance, without approval of the City Engineer, shall a street have a right-of-way width that is less than the street of which it is a continuation. Right-of-way requirements for widening at intersections shall be as specified by the City Engineer.

Building setbacks, landscaping requirements, and parking requirements shall be based on the ultimate right-of-way, regardless of the location of public street improvements.

A minimum 12.5-foot public utility easement (P.U.E.) shall be dedicated adjacent to all public and private streets and shall include traffic control appurtenances. Additional easement for sewer, water, storm drainage, landscaping, fencing, and all other public utilities shall be provided as required by the utility companies, these Design Standards, and as specified by the City Engineer.

Along the frontage of collector and arterial roadways, the right-of-way dedication shall include the landscape corridor adjacent to parcels zoned single-family residential (SFR).

7-3 ROADWAY SIGNAGE AND STRIPING - Signing and striping shall conform to the latest edition of the California Manual of Uniform Traffic Control Devices, (CMUTCD), unless modified by these standards, the Construction Standards, or in writing by City Engineer.

7-4 STRUCTURAL SECTION – All roads, both public and private, to be constructed within the City of Roseville shall be asphalt concrete over aggregate base and, if necessary, aggregate sub-base. It's desirable to the City to have all arterial roadways designed and constructed with the two-inch top lift of asphalt concrete, rubberized asphalt concrete material. Collector, residential and alley ways shall be designed and constructed with Type A, 1/2 –inch maximum medium asphalt concrete mix as described in the City's Construction Standards.

All pavement sections shall be designed on the basis of the resistance R-value as determined in accordance with the State of California, Department of Transportation design method and appropriate traffic indices (TI). If the subgrade has an "R" value of 10 or less, a geotextile fabric or other approved product shall be installed on subgrade prior to placement of AB or ASB material. In addition, the City Engineer may require the installation of edge drains in soils where the "R" value of the subgrade is 10 or less. The Geotechnical Engineer may submit for treatment of the subgrade material, with lime or cement or other approved product if suitable soils exist. This may be considered in lieu of geotextile fabric and base material with approval of the City Engineer.

Minimum TI values shall be as specified in Table 7-2 or as determined by City Engineer. At the discretion of the City Engineer, design traffic indexes (TI's) may be revised to reflect designated truck routes and/or where

projected future traffic volumes, based upon the City’s Travel Demand Forecast Model, indicate increased or reduced trips.

TABLE 7-2

Street Classification	Minimum Traffic Index	Minimum Structural Section (Assumes R=50)		
		AC	AB	AS
Alley-Way	-	2"	6"	
Minor Residential	6	3"	8"	
Primary Residential	7	3"	9"	
Collector Non-Residential Collector	8	4"	9"	
Industrial	9	4"	7"	6"
Minor Arterial	10	5"	7"	6"
Major Arterial	11	5"	7"	8"

A. Structural Street Sections at Signalized Intersections – Pavement sections shall be designed by a Registered Geotechnical Engineer. Where traffic signals loops are anticipated or will be installed, the minimum structural section shall include 4" of AC on the minimum required AB for a length of 100-feet, from the curb return of the arterial street. When “cutting” in signal loops, the slot depth shall be cut to achieve a minimum of 1-inch cover over the loops.

7-5. CURB AND GUTTER REQUIREMENTS – Curb and/or gutter are required adjacent to all public and private streets. All sidewalk, curb and gutter shall be constructed of minor concrete conforming to the provisions in Section 71-5 (B) “Minor Concrete.

A. Type 1 Roll Curb and Gutter – Type 1 roll curb and gutter shall be installed adjacent to all single-family residential and duplex developments, poured monolithically with sidewalk. STD DWG #ST-17

B. Type 2 Vertical Curb and Gutter – Type 2 vertical curb and gutter shall be installed adjacent to all multiple residential, industrial/commercial developments, school and park sites, poured monolithically with sidewalk or as specified by City Engineer. STD DWG #ST-17

C. Type 6 Modified V-Gutter – Type 6 modified V-gutter may be used for alleys and parking lots. Type 6 modified V-gutter shall not be used in either public or private streets.

D. Cross Gutters – Cross gutters shall not be installed unless the intersection cannot be drained by an underground system. Installation of cross gutters shall be subject to the approval of the City Engineer.

7-6 SIDEWALK REQUIREMENTS – Sidewalks shall be constructed adjacent to all public streets. All sidewalks shall be Minor Concrete as specified in section 71-5B of the Construction Standards and shall conform to the provisions of Section 90 of the Caltrans Specifications. All sidewalks shall have a minimum thickness of six (6) inches on native soil, at 95% relative compaction, or four (4) inches thick with four (4) inches of AB at 95% relative compaction, and shall meet the following requirements:

A. Width – The required minimum width of sidewalks shall be as listed in Table 7-3 unless the project is located within a Specific Plan area. In such case, the sidewalk width shall conform to the appropriate Specific Plan Landscaping Guideline, which may be obtained from the City of Roseville Planning Department. The width of the curb shall not be considered as included in the width of the sidewalk.

TABLE 7-3

Street Classification	Sidewalk Width
Minor Residential – Attached Sidewalk	4 feet
Primary Residential – Attached Sidewalk	4 feet
Minor Residential – Detached Sidewalk	5 feet
Primary Residential – Detached Sidewalk	5 feet
Collector/Industrial – Attached/Detached Sidewalk	5 feet
Minor Arterial	8 feet
Major Arterial	8 feet

B. Slopes – Detached sidewalks shall have a maximum slope in the direction of travel of 5.0 percent unless otherwise approved by the City Engineer. If the longitudinal street grade is greater than 5.0 percent, the slope of the sidewalk shall not exceed the longitudinal slope of the street. Cross slope shall be a minimum of 1.0 percent and maximum of 2.0 percent sloped downwards towards the gutter.

C. Radius – Detached meandering sidewalks shall have a minimum radius of 50 feet.

D. Pedestrian Curb Ramps – Pedestrian curb ramps shall be provided at all intersections and Type A-7 driveways. All curb ramps shall conform to the requirements of these standards and the City’s Construction Standards for slope criteria and standard design. It is the design engineer’s responsibility to ensure that the intersection slopes designated on the improvement plans allow for the construction of pedestrian curb ramps that meet the above criteria.

At “T” intersection located at signalized intersections, ramps shall be constructed in the appropriate position on the side of the through street, directly opposite the ramps at the curb return of the “T” intersecting street. Such ramps are not required on the side of the through street on residential streets unless the distance to the next available street crossing is greater than 500 feet.

E. Sidewalk Barricades – Sidewalk barricades shall be required where satisfactory provisions cannot be made for pedestrians to safely continue beyond the terminus of the sidewalk. Where sidewalks end in fill area, the fill shall be extended beyond the end of the sidewalk for a minimum distance of six feet.

7-7 PEDESTRIAN WALKS AND BIKE PATHS – Pedestrian walks within a development shall have a minimum easement width of 8 feet and sidewalk width of 5 feet. All walks shall conform to the requirements of Title 24. Walks shall be constructed with a minimum thickness of six inches of Portland cement concrete, Minor Concrete as specified in Section 71-5B of the Construction Standards.

Bike paths design shall conform to Section 13 of these Standards. Combined pedestrian/bike paths (See Class 1A Bikeways within Section 13) shall be a minimum of 12 feet wide and be constructed of either Portland cement concrete, per section 71-5B, having a minimum thickness of 4 inches or 2 inches of asphalt concrete over 4 inches of aggregate base.

Pedestrian walks and Class 1A bike paths, if situated between lots, including paseos, shall be fenced with chain link fencing or other material as approved by the City of Roseville Development Services Department and shall extend from the street right-of-way to the back lot line. These fences shall be 6 feet high from the building setback line to the back lot line and 3 feet high from the building setback line to the street right-of-way line. Collapsible bollards shall be placed at both ends of all these pedestrian walks/Class 1A bike paths.

See Section 13 for other requirements for bike paths.

7-8 ROADWAY PROFILE STANDARDS – The following standards shall apply to the design of roadway profiles. Also refer to Section 3 of these Design Standards.

A. Grades – The minimum centerline (longitudinal) grades on new streets and gutter flow lines shall be 0.35 percent. The maximum street slope shall limit 5 percent except where a steeper street is determined necessary by the City Engineer due to existing topographical features. The minimum grade of gutter sections constructed along existing streets shall be 0.20 percent.

- B. Cross Slopes** – Standard cross slopes shall be 2.0 percent on all roadways. Certain roadways may require super elevations as directed by the City Engineer. Cross slopes on widened existing streets shall be a minimum of 1.5 percent and maximum of 3.0 percent. Where a street constructed with a super elevation is to be widened, the cross slope shall be as specified by the City Engineer.
- C. Vertical Curves** – The minimum allowable vertical curve length at the intersection of two grades shall be 50 feet; however, vertical curves may be omitted where the algebraic difference in grades does not exceed 2.0 percent. When vertical curves are required, they shall provide for adequate sight distance based on the minimum design speeds specified in Table 7-4. The vertical curve data shall be computed and shown on the plans and shall call out the tangent gradient length of curve, the elevations and stationing points of the beginning of vertical curve (BVC), end of vertical curve (EVC), PI, high and low points and along 25 foot intervals.
- 7-9 INTERSECTIONS** – Street centerlines shall intersect one another at an angle as near to a right angle as is possible by tangents not less than 100 feet in length. In unusual circumstances the City Engineer may waive this requirement. Refer to Standard Drawings for required rights-of-way, pavement, taper lengths, etc. for intersections involving minor and major arterials.

At intersections, where two streets intersect, the centerline grade of the major street shall have a maximum centerline (longitudinal) grade of 2.0 percent for a minimum distance of 40 feet measured from the curb line of the intersecting street, except in unusually rough terrain, as determined by the City Engineer. The centerline of the minor street shall meet the crown slope at the projected lip of gutter. Crown slope may be reduced to 1.0 percent within the intersection if necessary.

- 7-10 OFFSET INTERSECTIONS** – The following requirements apply to all offset intersections. Any variation to these requirements shall be subject to the approval of the City Engineer. **Distances are measured from centerline to centerline.**
- A.** Residential streets intersecting another residential street from opposite sides shall have their centerlines meet, or the offset between intersections shall be a minimum of 150 feet.
- B.** Minor and primary residential streets intersecting collector streets from opposite sides shall have their centerlines meet or the offset between the intersections shall be a minimum of 200 feet.
- C.** Minor and primary residential streets, and collector/industrial streets intersecting minor or major arterial streets from opposite sides, shall have their centerlines meet or the offset between the intersections shall

be as shown on standard drawing ST-47. This condition shall not apply where a raised center median is provided on the major street separating conflicting turning movements.

D. Intersections between two arterials shall have their centerlines meet, or the offset between the intersections shall be a minimum of 1320 feet.

7-11 ELBOW INTERSECTIONS – Use of expanded corners shall be limited to projected low volume residential, commercial and industrial streets and conditions where conformance to minimum horizontal length of centerline radius is not practical, and shall be subject to approval of the City Engineer.

7-12 DESIGN SPEED SIGHT DISTANCES

A. Stopping Sight Distance – The minimum stopping sight distance over any segment of roadway shall be designed for the vehicle speeds listed in Table 7-4 unless specific approval for a lesser design speed is received from the City Engineer. Minimum stopping sight distance shall be consistent with that specified in the latest edition of Caltrans Highway Design Manual, Section 201.1. The design stopping sight distance requirement is based on 3.5-foot height of eye and a 6-inch height of object.

**TABLE 7-4
 ROADWAY DESIGN SPEEDS**

Street Classification	Roadway Design Speeds	Required Stopping Sight Distance
Minor Residential	25 mph	150 feet
Primary Residential	30 mph	200 feet
Industrial/Collector	40 mph	300 feet
Minor Arterial	50 mph	430 feet
Major Arterial	60 mph	580 feet

B. Sight Distances For Cars Entering Side Streets or Driveways via Left Turn In – The design of left turns from public and private roadways entering streets and driveways (as shown in Exhibit 7-1) shall provide minimum sight distance in accordance with Table 7-5 (single family residential exempt).

**TABLE 7-5
 SIGHT DISTANCE FOR CARS ENTERING
 STREETS/ DRIVEWAYS BY LEFT TURN**

Street Classification	Required Sight Distance
Industrial/Collector	440 feet
Minor Arterial	605 feet
Major Arterial	785 feet

Taken from the 2004 AASHTO Geometric Design of Highways and Streets

**EXHIBIT 7-1
 LEFT TURN SIGHT DISTANCE:**

SIGHT DISTANCE FOR CARS ENTERING SIDE STREETS OR DRIVEWAYS VIA LEFT TURNS.

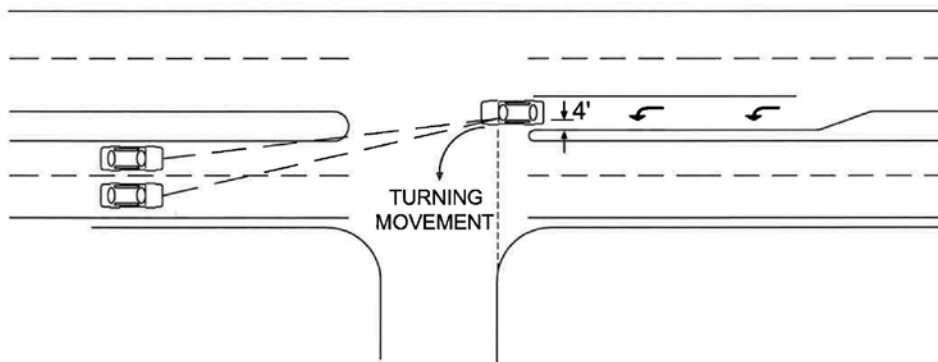

Sight Distance is based on a 3.5 foot height at the location of the driver and a 4.25 foot object height in the center of the approaching lane of the major road. The left turn driver measurement is taken 4 feet from the left edge of the turn lane at the projected edge of the curb return (as shown above). If the major road is a multi-lane road, the controlling measurement for sight distance shall be based on the approach lane that is the worst case scenario.

C. Corner Sight Distances for Cars Exiting at Intersections and Driveways – The design of all public streets, private streets, and major non-residential driveways (as shown in Exhibit 7-2) shall provide minimum sight distance in accordance with the following requirements. Design speeds and the corresponding minimum required corner sight distance shall be as specified in Table 7-6. Minimum corner sight distance shall be consistent with that specified

in the latest edition of Caltrans Highway Design Manual, Section 405.1A.

**TABLE 7-6
 DESIGN SPEEDS FOR CORNER SIGHT DISTANCE**

Street Classification	Corner Sight Distance Design Speed	Required Corner Sight Distance
Minor Residential	30 mph	330 feet
Primary Residential	35 mph	385 feet
Industrial/Collector	45 mph	495 feet
Minor Arterial	55 mph	605 feet
Major Arterial	60 mph	660 feet

**EXHIBIT 7-2
 CORNER SIGHT DISTANCE:**

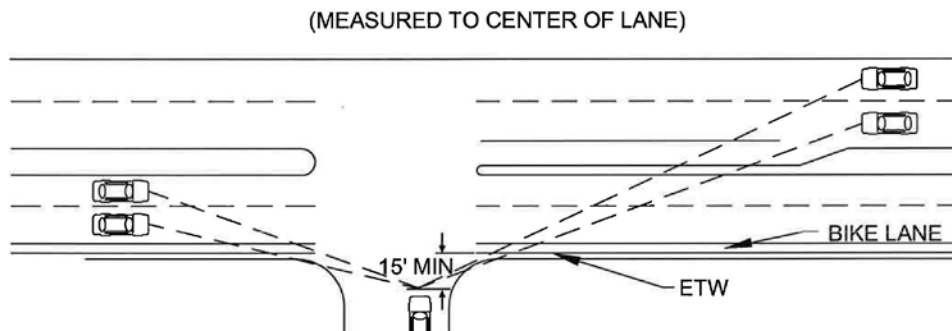

Setback for the driver of the vehicle on the crossroad shall be a minimum of 10' from the edge of travel way plus the shoulder width of the major road, but not less than 15 feet as shown above. Line of sight for corner sight distance is to be determined from a 3.5 foot height at the location of the driver of the vehicle on the minor road to a 4.25 foot object height in the center of the approaching lane of the major road. (Highway Design Manual section 405.1(2)(a)). If the roadway being entered is a multi-lane road, the controlling measurement for sight distance shall be based on the approach lane that is the worst case scenario.

7-13 CENTERLINE RADII – The curve data (delta angle, length, tangent and radius) for all centerline curves shall be computed and shown on the plans. The minimum centerline curve radii shall be as specified in Table 7-1.

Special consideration may be given by the City Engineer for unusually difficult alignment problems.

7-14 DRIVEWAYS – When driveways are abandoned or relocated, the driveway section shall be removed and replaced with curb, gutter, and sidewalk conforming to these standards. Parking is restricted within the throat depth of all driveways. All new driveways shall conform to the following requirements:

A. Types, Widths and Grades

1. Single Family Residential and Duplex Driveways shall have a minimum throat width of 16 feet and maximum throat width of 32 feet.

Lot pads shall be graded to accommodate maximum driveway slopes of 14 percent from back of right-of-way. Unusual terrain conditions may warrant waiver of this design subject to the approval of the City Engineer. Number of driveways accessing a single parcel is defined in Section 5-4 “Site Access” of these Design Standards.

2. Multi-Family/Office Commercial/Industrial Driveway main entrances shall have a minimum throat width of 35 feet. The minimum throat width may be reduced to 25 feet if the driveway is a secondary access or restricted to right turn movements. If a raised median is provided in the driveway throat, the driveway width shall be widened as necessary to accommodate the number of ingress and egress lanes required, with a minimum ingress lane width of 18 feet. The minimum driveway median width shall be 4 feet and the maximum width shall be 10 feet. The nose of the median shall be no less than 7 feet and no more than 15 feet from the gutter flow line.

Driveways located on collector streets shall be standard commercial driveways per the Standard Drawings unless the City Engineer deems a Type A-7 driveway appropriate for a particular project. Driveways on arterial streets shall be either at grade with appropriate drainage collection facilities or “Type A-7” per these Standards.

Driveway slopes shall have a maximum grade of 10 percent except from the edge of pavement to a distance 15 feet within the project. This area shall have a maximum slope of 2 percent. Unusual terrain condition may warrant waiver of this requirement subject to the approval of the City Engineer. If the driveway is other than a “Type A-7” driveway that provides cross gutter, a traffic control sign shall be provided.

B. Location – All aspects of site access (location of driveways, number of driveways allowed, spacing of driveways, etc.) are addressed in Section 5 of these Design Standards.

C. Sight Distance – Sight distance at driveways shall be as specified in Section 7-12.

7-15 BUS STOPS AND TURNOUTS – Bus turnouts and shelter pads shall be required at locations specified by the City Engineer. All bus turnouts shall conform to the STD DWG #ST-29. The size and location of bus shelter pads, whether existing or proposed, shall conform to STD Drawing ST-28 and shall be shown at all bus turnouts.

“Bus stops with or without shelters, shall have a concrete bus stop pad, with minimum dimensions of 8-ft long as measured perpendicular from the face of curb and 5-ft wide as measured parallel to the curb. Bus stop pads are to be kept clear of bus shelters and other street furnishings including bike racks, trash cans, street lights, and other vertical objects.”

7-16 DEVELOPER RESPONSIBILITY FOR IMPROVEMENTS TO STREETS

The following requirements apply to private development project adjacent to existing and proposed streets.

A. The Developer shall be responsible for upgrading streets within and adjacent to the developer’s project where the pavement section of an existing street does not meet the structural section and/or the centerline grade and alignment requirements specified in these Design Standards for those streets.

Where the design centerline grade is to be higher than the existing, the Developer shall extend the overlay beyond the centerline of the street and shall neatly conform to the existing surface grade on the other side. The Developer shall also be responsible for overlaying any low areas where the new pavement is proposed to meet the existing pavement to maintain a uniform cross slope.

B. When making a connection to an existing stub street, the Developer shall be responsible for removing and reconstructing up to a maximum of twenty feet of the existing roadway to make a satisfactory connection as required by the City Engineer.

C. When widening to complete an existing partial street along a development project, or when removing existing curb and gutter, the Developer shall be responsible for saw cutting and removing a narrow strip along the outside portion of the pavement to provide a clean and stable pavement section for constructing against. Grinding of existing pavement (1½-inch minimum) shall be made to the next nearest edge of lane line. The width to be removed shall be determined by the City

Engineer. In the case of curb and gutter removal, minimum width of pavement cut shall be 2 feet.

- D.** All temporary approaches to existing roadways required as a result of the development shall be at the Developer's expense. The temporary approaches shall be paved with the structural section to be determined individually for each situation.
- E.** The Developer shall be responsible for relocating existing traffic signals and streetlights, and installing new traffic signals and street lights as necessary for new street and driveway locations. The Developer shall also be responsible for relocating existing traffic signals and street lights as necessary for the installation of new curbs or new curbs and sidewalks at locations where there are no existing curbs or curbs and sidewalks, or, where existing improvements do not meet current standards. Traffic signals must remain operational during all construction within signalized intersections.
- F.** The Developer shall be responsible for constructing or modifying median island curbs where required by these standards, or when required for traffic control as a result of the development, as determined by the City Engineer.
- G.** The Developer is required to provide frontage improvements along existing and proposed roadways at the Developer's expense. Frontage improvements include, but are not limited to, sidewalk, curb and gutter, center median, 18 feet pavement width, additional pavement width beyond the 18-foot for intersection widening (including acceleration and deceleration lanes, bus turnouts, widening for dual left turns, etc.), drainage system, landscaping, soundwalls, street lighting, roadway signing and striping, and all utilities (including traffic signal interconnect if applicable). For minor residential, primary residential, collector and industrial streets, the Developer shall provide the full right-of-way improvement.
- H.** For development within the "infill" areas of the City, the level of improvements to public streets adjacent to the development site shall be determined on a project specific basis at the discretion of the City Engineer.
- I.** The Developer shall be responsible for all drainage facilities (bridges, pipes, culverts, and appurtenances) crossing new streets within or adjacent to the project.
- J.** The Developer shall be responsible for all necessary modifications within the public right-of-way and the project site to comply with state and federal standards for access for disabled, including but not limited to sidewalk ramps.

7-17 TRENCHING IN EXISTING PAVED ROADWAYS – All trenching in existing roadways shall conform to the Standard Drawings and the Construction Standards. The Developer may be required to coordinate trenching work schedules to avoid cutting pavement where repaving is planned by the City. All cuts within a paved street shall be subject to the City’s Trench Cut Ordinance. The Trench Cut Ordinance fee shall be paid prior to the approval of any plans. In no case will trenching be permitted on any street that has been constructed or overlaid within the last five years (Moratorium Streets). The City Engineer under unusual circumstances may give special consideration.

7-18 STREET NAMES AND STREET NAME SIGNS – Street names shall be proposed by the Developer and shall be shown on the tentative map when submitted. These names shall be subject to approval by the City Council. No duplication of names already in use or previous proposed or sound alike names will be permitted. Street name signs shall be furnished and installed by the Developer. The requirements for location of signs do not apply to signalized intersections since signals will have their own street name signs. Street name signs shall conform to City of Roseville Construction. Refer to Roseville Construction Standards Section 56 “Signs”.

A. Location and Number Required – The required number of street name signs installed and location, depends upon the width of street right-of-way and shall conform to the following:

Case 1 – Two street name sign installations (with four sign plates on each post) are required at each intersection where one or both of the intersecting streets are a collector or arterial street. At a four-way intersection, the installations shall be located on both far right hand corners of the intersection relative to the direction of travel on the street having the greater right-of-way width or on the major street if right-of-way widths are equal.

At a “T” intersection, one sign shall be installed on the far right hand corner of the intersection relative to the direction of travel on the through street and the other shall be installed along the left side of through street relative to the direction of travel at a point directly opposite the centerline of the “T” intersecting street. One sign plate should be omitted from the standard four-plate installation at the “T” intersection sign locations where an approach street does not exist.

Street name signs shall be located adjacent to the major street at the end of the curb return.

Case 2 – One street name sign installation (with four sign plates on each post) is required at each intersection where both intersecting streets are residential streets. At a four-way intersection, the

installation shall be located at one of the far right hand corners of the intersection relative to the direction of travel on the street having the greater right-of-way width or on the major street if the right-of-way widths are equal.

At a "T" intersection, the installation shall be located on the far right hand corner relative to the direction of travel on the through street.

Street name sign shall be located at the midpoint of the curb return.

Case 3 – For arterials with frontage roads, the street name sign installations shall be located in the divider strip between the frontage road and the main traveled way of the highway at the near side of the intersection. All other requirements shall be as outlined above, except that only one sign will be required (in the divider strip in line with the centerline of the minor street) when there is no opening in the divider strip for access to main highway.

7-19 SURVEY MONUMENTS – The consulting engineer shall place survey monuments at the following locations:

- A. At the intersection of street centerlines.
- B. At the beginning and end of curves on the street centerline.
- C. At the center of all cul-de-sacs and elbow points.
- D. At the subdivision boundary corners and at such other locations so as to enable any lot or portion of the improvements to be retraced or located, as directed by the City Engineer.

The above-described monuments shall be as follows:

- 1. Subdivisions boundary monuments except those in street pavement shall be not less than 1-inch solid steel or 1-³/₄ inch galvanized iron pipe 30 inches in length, capped and tagged.
- 2. Subdivision monuments in street pavements shall be no less than a ³/₄ inch galvanized iron pipe, 18 inches in length. Top of pipe shall be driven flush with surface pavement.
- 3. All monuments in street pavement shall be monument wells, conforming to the standard drawing and shall be Detail ST-36 and shall be placed at all street intersections, centers of street cul-de-sacs and elbow points. In addition, monument wells shall be required on street centerlines and located such that there will be a clear line of sight distance between the two monuments within the

street right-of-way. These will normally be located at points of curvature not exceed 1000 feet.

4. Lot corners shall have a ½ inch rebar at rear corners. Front corner and side lot lines shall be projected and marked on the back of sidewalk with a sawcut score mark 4 inches long and ¼ inches deep or 1 inch brass marker.
5. Permanent survey monuments shall be placed by the Consulting Engineer at all section and quarter corners within the development. The section corner monuments shall be Class “B” concrete, poured in place, with minimum dimensions of 6” diameter x 24” deep, with a brass cap in accordance with Bureau of Land Management Standards.

All such monuments shall be referenced to permanent objects located nearby and all ties shall be furnished to the City Engineer for general public use. Final acceptance of the public improvements will not be made until such ties have furnished to the City Engineer.

The Consulting Engineer shall also place a note on all construction plans stating that the Contractor is responsible for the protection of all existing monuments and other survey markers.

7-20 BENCHMARKS – In locations where a new benchmark will be required, as determined by the City Engineer, the Consulting Engineer’s Land Surveyor (L.S.) will set in concrete a 3¼ inch brass cap, provided by the City Engineer. The L.S. shall then run a second order, class two closed loop survey from an approved City of Roseville benchmark to establish the U.S.G.S. elevation of the cap. The level notes shall include the new benchmark elevation in North American Vertical Datum of 1988 (NAVD 88) and National Geodetic Vertical Datum of 1929 (NGVD) vertical datum. The L.S. shall also include the California II State Plane Coordinate values if the new benchmark in North American Datum (NAD 83). All new benchmarks shall have a NGS stability rating of A or B. The level notes shall be submitted to the City Engineer for review and approval.

Licensed Surveyors recovering existing benchmarks for use in their work and for work with Consulting Engineers shall provide the City Engineer with the elevation of the recovered benchmarks in NAVD 88 and NGVD 29 vertical datum. The L.S. shall also provide the City Engineer with the California II State Plan Coordinate values for recovered benchmarks.

After approval of the notes, the new benchmark will be assigned a number that the developer’s engineer will mark on the brass cap, along with the date, and R.C.E. or L.S. number of the person certifying the level notes.

Benchmarks shall be provided where specified by the City Engineer and at all culverts 60-inches or greater, bridge crossings passing a 100 year flow of 250 cfs or greater, and within subdivisions that are greater than 60 lots.